

# WISI LR 27 W xxx2

Node for RFoG Systems incl. PON Filter



## At a glance:

- High RF output level of 109 dB $\mu$ V for a full DOCSIS 3.1 load in FTTC or FTTB networks
- DOCSIS-3.1-compliant frequency range: Downstream up to 1.2 GHz, Upstream up to 204 MHz
- Pluggable diplexers enable migration towards DOCSIS 3.1 upstream
- Pluggable output splitters / taps for flexible configuration of the two RF outputs
- PON pass-through port for CATV overlay signals in single-fiber FTTx networks
- Device control via bluetooth app or via handset OH 41
- Optional: Remote control compliant to IEC 60728-14 via FSK receiver module
- Compact housing for outdoor deployment (IP66)
- Optical ALC for regulated output levels

## Description

The LR 27 W Fiber Node is an optical node for RFoG applications including PON filters. They can be operated in RFoG mode (burst-mode) and HFC mode (continuous wave).

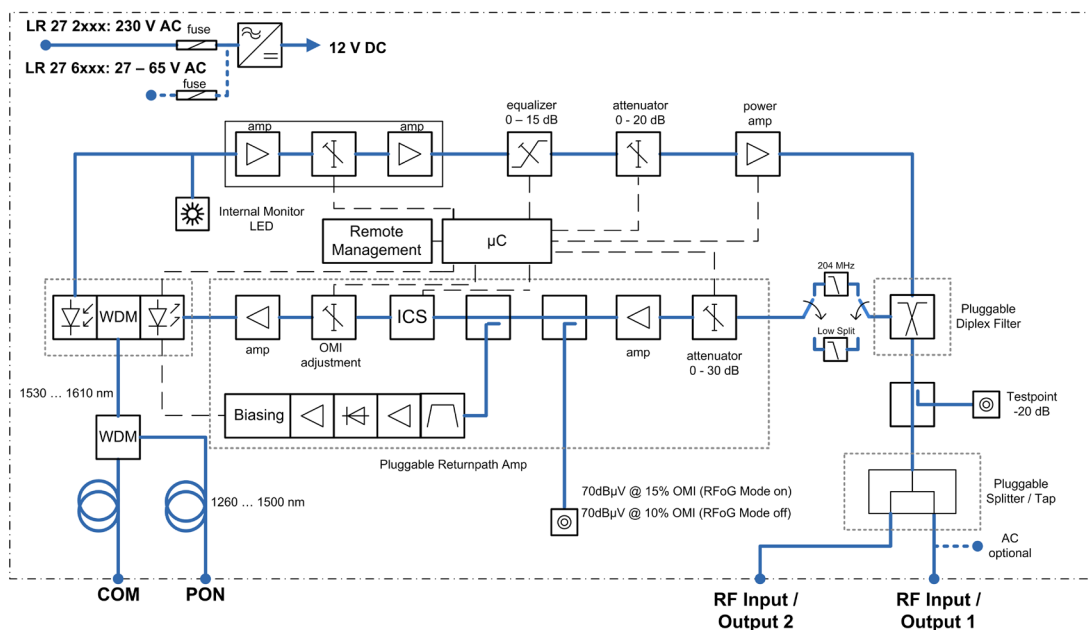

**WISI Communications GmbH & Co. KG**

Wilhelm-Sihn-Str. 5-7  
75223 Niefern - Oeschelbronn, Germany

Phone: +49 7233 66-280, Fax: -350  
E-Mail: export@wisi.de

Technical Modifications reserved. WISI cannot be held liable for any printing error. 8. April 2019, 1:25 nachm.

## Technical data

Downstream	
Optical input power	-8...+2 dBm
Wavelength	1535...1565 nm
Frequency range	85...1218 MHz (depending on diplexer)
Noise current density	< 4,5 pA/√Hz
Attenuator downstream	0...20 dB (0,5 dB steps)
Equalizer downstream	0...15 dB (0,5 dB steps)
Outputlevel 10 dB slope (121 x QAM256), (EN60728-3-1)	109 dBμV (BER <1 exp-9), (@ 2,5% OMI)
Outputlevel flat (121 x QAM256), (EN60728-3-1)	107 dBμV (BER <1 exp-9), (@ 2,5% OMI)
Amplitude response	±0,75 dB
Test point	-20 dB
RF return loss	> 18 dB (-1 dB/oct., min. 14 dB)
Optical return loss	> 40 dB
Upstream	
Optical output power	2,5 dBm (±0,5 dBm)
Wavelength	1610 nm (according Order Code)
Frequency range	5...65 / 204 MHz (depending on diplexer)
Flatness	±0,75 dB
Low pass (switchable)	85/204 MHz or 65/204 MHz (see order code)
Ingress Control Switch (ICS)	0/-6/- >45 dB
RF return loss	> 18 dB
Optical return loss	> 40 dB
RFoG-Upstream (RFoG Mode „on“)	
RF input level	70...100 dBμV
Attenuator	0...30 dB
Test point	70 dBμV (@ 15 % OMI)
HFC-Upstream (RFoG Mode „off“)	
Nominal RF input level	70 dBμV (5 % OMI)
OMI	3...10 % (adjustable)
Test point	70 dBμV @ 10 % OMI
PON-WDM	
PON wavelengths	1260...1500 nm
PON insertion loss	<1 dB
Isolation COM -> RF downstream	>45 dB
Isolation COM -> PON	>25 dB
Isolation PON -> RF-Downstream	>45 dB
Interfaces	
Optical connectors	SC/APC (see order code)
PG 11 connectors	4 pcs. (2x RF input/output)
User interfaces	
Status LED downstream	Optical input power
Status LED upstream	Laser activity
Management ports RJ11	1 pcs. (for handset OH 41)
Remotely controlled parameters via FSK	DS on/off, US on/off, ICS 0/-6/-45 (with optional Rx module)
Bluetooth version	4.0 / LE
Bluetooth app compatibility	Android 4.3 or higher

## Technical data

General data	
Supply voltage	LR 2x x 2xxx: 180...264 V AC, LR 2x x 6xxx: 27...65 V AC
Power consumption max.	16 W
Output impedance	75 Ω
Dimensions (width x height x depth)	232 x 145 x 86 mm
Electro Magnetic Compatibility (EMC)	EN 50083-2
Protection class	IP 66
Ambient temperature	-10...+55 °C

## LR 27 W XXX2

### Upstream Wavelength:

- 27 – 1270 nm
- 29 – 1290 nm
- 31 – 1310 nm
- 33 – 1330 nm
- 35 – 1350 nm
- 37 – 1370 nm
- 39 – 1390 nm
- 41 – 1410 nm
- 43 – 1430 nm
- 45 – 1450 nm
- 47 – 1470 nm
- 49 – 1490 nm
- 51 – 1510 nm
- 53 – 1530 nm (on special request only)
- 57 – 1570 nm (on special request only)
- 59 – 1590 nm
- 61 – 1610 nm

### Power Supply:

- 2 – 230V local powered
- 6 – 65V remote powered

### Connection Options:

- W – including optical filter

### Typ of Node:

- 7 – Single Fiber RFoG Node (Standard)